

## **New Mexico State Fair Indoor Exhibit Size Guidelines**

### **Posters**

Posters may be no larger than 14 x 22 inches (this is half of a standard sheet of poster board). Posters are defined as any flat paper, foam board, cardboard, or other backing appropriate for hanging on the wall for display. Flat items placed on stands or with stands attached will be considered posters and the stands will not be utilized for display.

### **Display Boards**

Display Boards may be no larger than 18 x 48 inches (this is a small size display board, or half of a standard display board.) Display boards are defined as scored, freestanding science boards that may be purchased at any school supply store. These are boards made freestanding by the sides being folded in slightly.

### **Other Exhibit Boards**

Exhibit bases for three dimensional vertical displays may be no larger than 24 x 24 inches. A vertical display is defined as an exhibit with a solid base where the exhibit itself rises up. This would apply to small engines, Self-Determined, or any other appropriate 3-D Display.

### **Project Specific Boards**

Some project boards are given specific measurements within the project. For example, Leathercraft and braiding have guidelines in the project book. If an exhibit is defined by the project book that is the rule members must follow.

### **Photography Entries**

Single photographs (3½" x 5", 4" x 6", or 5" x 7" prints) must be mounted on an 8" x 10" backing without frames or glass, with a caption. Sets of photographs (3½" x 5" or 4" x 6" prints) should be mounted on an 11" x 14" backing without frames or glass, with a caption. Backing needs to be sturdy enough to support photo and travel well. Posters and Display Boards entered in the Photography Category must meet the requirements as listed above.

### **Oversized Items**

Because of security and space limitations, extremely large/heavy project exhibits may not be accepted for display in the 4-H Department; call (505) 646-1166 for prior approval on large Woods, Welding or other large exhibits. This only applies to actual items – posters, display boards, and vertical displays may not be over-sized. We can not guarantee that oversized items will be placed behind glass.

### **Enter at your own risk.**

All items are entered at your own risk. While we do our best to handle each item carefully and respectfully, there is always some risk of damage.

### **Display to the best of our ability.**

All items are displayed to the best of our ability. Cases will not be opened to move items, the exception being if items are upside down or mislabeled.

### **Pre-registration and Entry Day**

Each County is responsible for their own entries. There will be no early drop-off of entries. Entries received with incorrect numbers will be returned to that County for renumbering.

### **Youth Officials**

Youth Officials are required to stay in the dorms for the duration of their service.

**4-H Exhibit Booths**

Any county wishing to reserve a 4-H Booth must make a \$20 deposit. If the county sets up their booth, they will get the \$20 back, if not, the money will go into a fund to repair the booths. Reservations will be taken beginning in July. If a deposit is not paid by August 15, the booth will go to the next county on the waiting list.

**New Classes**

Consumer Classes will be broken out into Level 1 Exhibit, Level 2 Exhibit, etc.

**Posters** – flat displays appropriate for hanging on the wall.

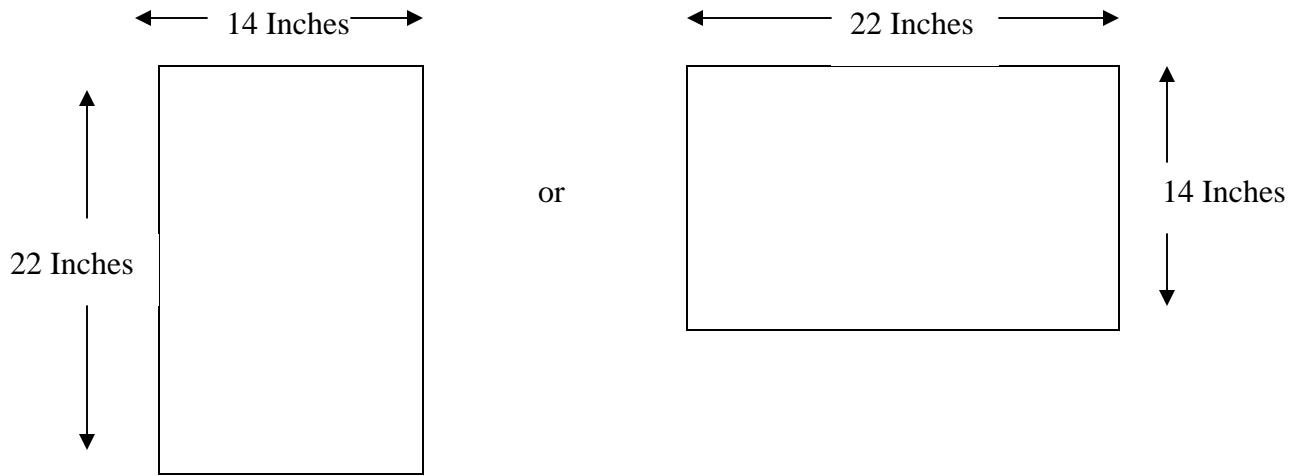

**Display Board** – scored, freestanding science board

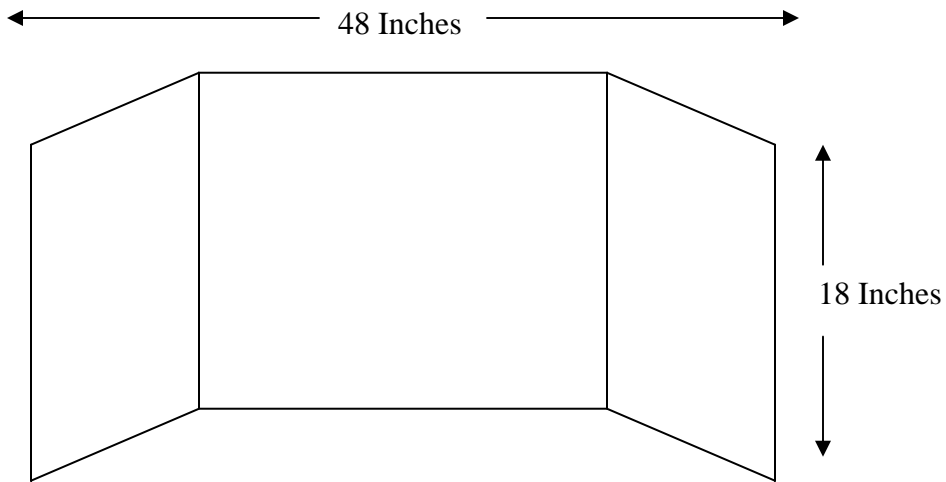

**Vertical Displays** – solid base with a 3-D exhibit that rises from it

